

WISE

JUMP SEAT ASSEMBLY INSTRUCTIONS

MODEL NO'S.

• Applicable for all Jump Seats

- Phillips head screwdriver is the only tool required
- By shipping this product to you unassembled, freight costs are greatly reduced

A

- Set up side panels **B** and **C** parallel to each other with the square face to front.
- Slide front panel **D** into notch on both side panels simultaneously.
- Slide black spacer bar **E** into U-shaped holes at bottom of side panels.

B

- Slide back rest **A** downward into notches at rear of base.

C

- Attach 4 screws into bottom side corners of base through pre-drilled holes, one in each corner.
- Attach 2 screws through base bottom into black spacer bar

D

- Snap seat cushion down onto base with black square to front.

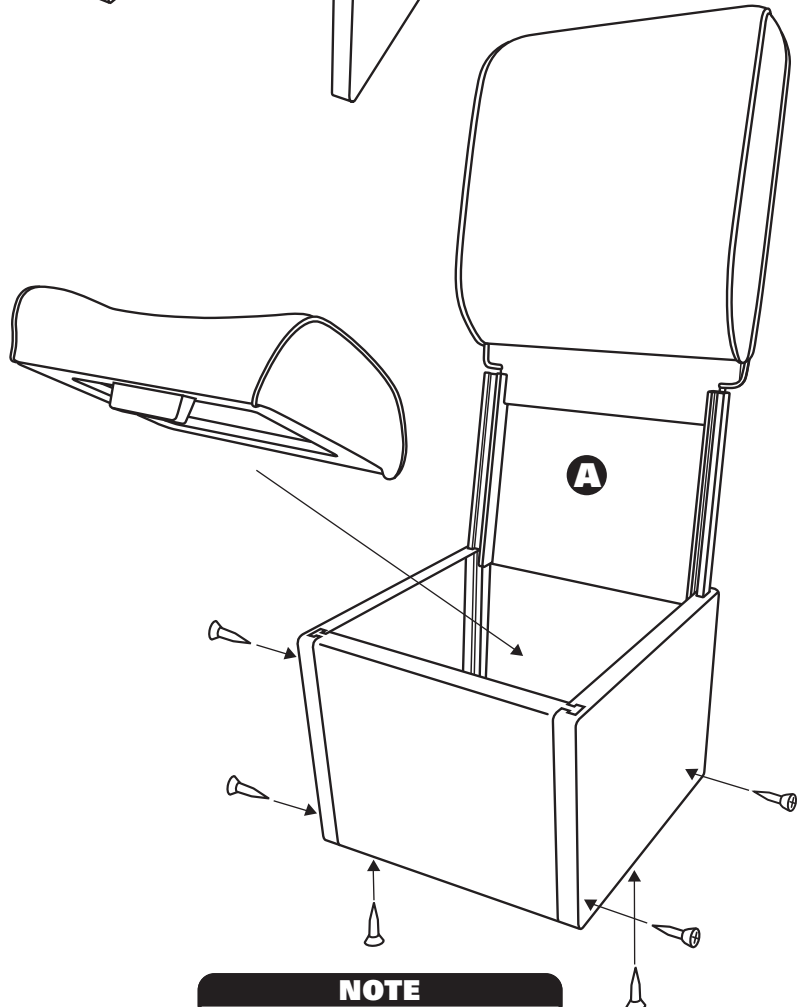
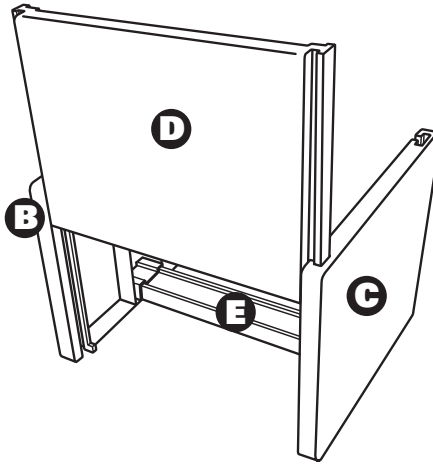

NOTE

TO AVOID CROSS-THREADING
OF FASTENERS PLEASE START
ALL SCREWS BY HAND

**Questions? Missing Parts?
Call 1.800.759.5769**

Above items are not manufactured
for commercial use.

WF 1135
3.25.08

THE WISE COMPANY

MANUFACTURERS OF QUALITY MARINE SEATING SINCE 1960

472 WEST 9TH ST., RECTOR, AR 72461 • TOLL FREE TEL: 1.800.759.5769 • www.wiseseats.com