



Taylor Made  
PRODUCTS®

## Installation & Operation Instructions Models 6205D, 6208D & 6210D



### IMPORTANT

#### Installer/Rigger Information

The Taylor Made D-Icer is a powerful, submersible, motor-driven water circulation device designed to prevent ice formation during winter months. By continuously moving warmer water to the surface, the Taylor Made D-Icer keeps the area ice-free. It's ideal for use around a boat or dock, and can be used for aeration of industrial lagoons and aqua culture, fish ponds and net ponds.

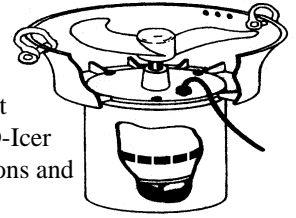

### WARNINGS

- Never suspend the D-Icer by its power cord. Suspending the unit by its power cord may result in serious personal injury or equipment damage.
- The D-Icer must be plugged into a ground fault circuit interrupter (GFCI) equipped outlet. Failure to use a ground fault protected outlet may result in serious personal injury.
- The D-Icer motor is protected from overheating by a thermal breaker. Overheated motor may restart at any time. Always disconnect power from outlet before handling unit. Handling D-Icer with power connected may result in serious personal injury.

### PERSONAL PRECAUTIONS

1. Someone should assist you with installation of unit. Lowering the unit and removing the unit typically requires two people.
2. Wear gloves when installing or removing the D-Icer.
3. Never attempt to remove the D-Icer while it's running.
4. The D-Icer motor is protected from overheating by a thermal breaker. Overheated motor may restart at anytime. Always disconnect power from outlet before handling unit. Handling D-Icer with power connected may result in serious personal injury.
5. Never remove the ground plug. You must use a grounded outlet with a ground fault circuit interrupter (GFCI) or serious injury may result.

### MOUNTING LINES

The shape of the area to be protected by the D-Icer can be varied by hanging it at different angles, see Figure 1. Connect the shackles to different holes in the D-Icer shroud to vary the angle. For a circular pattern connect the shackles to the holes further from the centerline of the D-Icer (holes 3 - 6) will create an elongated protected area. Some experimentation will be required to optimize the pattern for your particular situation.

**Never attempt to adjust the D-Icer while it's running.**

**Figure 1 -**

D-Icer™ top view showing mounting hole pattern.

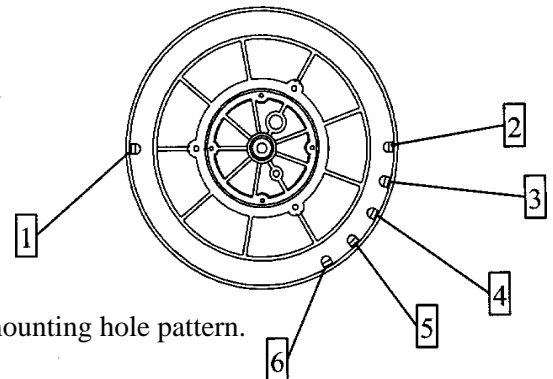

### A User Note about Starting the Taylor Made D-Icer **DISCONNECT POWER FIRST!**

The shaft seals of the D-Icer keep water from entering the motor. New seals will be snug, and may become too tight if they sit dry for some extended time. This may make it difficult to start the propeller. Taylor Made recommends that you turn the propeller by hand a few turns, **with the power disconnected**, before attempting to start up the first time. This will help overcome the static drag from a dry seal. Thereafter, you should have no difficulty in operation.

When you set up to use the D-Icer again in a new winter season, it may also be helpful to give the propeller a few turns again, but be sure the **power is disconnected** before trying this. You could be seriously injured if you force the propeller free with power connected.

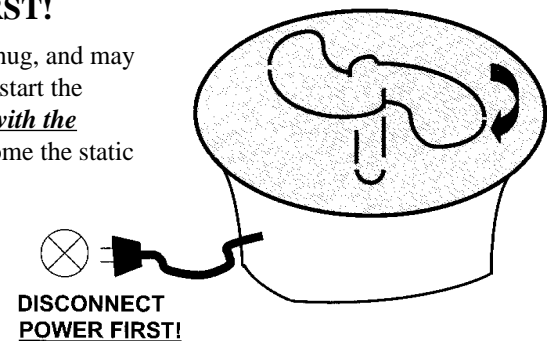

### INSTALLATION

Hang the D-Icer in the water by its two suspension lines. It should be hung approximately 3 -4 feet beneath the water's surface for best results. In tidal waters, the D-Icer can be hung from the boat to allow for the boat's rise and fall. Adjust its depth so that its average depth is 3 -4 feet. If hung from a boat, make sure the D-Icer will not bottom out at low tide. If hung from the dock, make sure the D-Icer will not hang out of the water at low tide. See Figure 3. Take care to rout the lines and power cord so that they are out of any traffic areas and do not interfere with D-Icer propeller. When mounting the D-Icer near a boat, make sure the D-Icer will not hit the hull when in use.

Cont. on back

## **INSTALLATION** (Continued)

### **Note:**

If an additional line is required, it should only be tied to the shackle in which the factory installed line is tied. If two additional lines are required, a single line should be used by tying the half-way point to the line to the same shackle in which the factory installed line is tied and then wrap the line around the housing and through the opposite shackle.

***Never suspend the D-Icer by its power cord.  
Hand tension only on suspension lines.***

### **OPERATION**

Plug the D-Icer into a ground fault circuit interrupter (GFCI) protected outlet rated for at least 15 amps. Check the flow pattern of the D-Icer. If any adjustments are required, unplug the D-Icer and make necessary changes. If you are using the thermostat attachment be sure to mount it in a secure location and free from the suspension lines.

### **MAINTENANCE**

Your D-Icer is designed for long life with a minimum of maintenance. The following simple maintenance procedures are all that is required for years of reliable operation.

#### ***Zinc Anode***

The zinc anode should be checked periodically for deterioration and replaced if severely corroded. Please note that if you live in a high growth area, you may want to check the zinc on a more frequent basis. The zinc replacements may be purchased from your local marine distributor.

#### ***Storage***

When removing the D-Icer from the water for the season it should be cleaned and rinsed with fresh water, and stored propeller side down in a cool place. This will keep the D-Icer seals lubricated.

#### ***Propeller***

The propeller will require replacement if it becomes damaged. To replace the propeller, unplug the D-Icer, grasp the zinc anode or motor shaft with pliers and turn the propeller counter-clockwise to remove it. To install a new propeller, simply reverse the removal procedure.

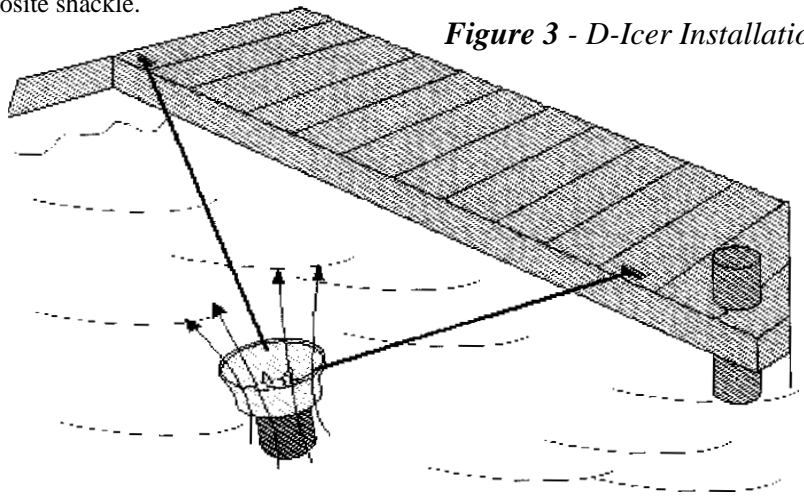

**Figure 3 - D-Icer Installation**

### **HOUSING**

Your D-Icer was designed with a state of the art protective black shroud. This special feature allows you to use the D-Icer in areas of extreme growth and debris. As a part of your maintenance routine, you should keep the propeller and shroud free from entanglements as needed.

***Never attempt to repair the D-Icer or remove the shroud!***

### **ACCESSORIES**

<b>Description</b>	<b>Part Number</b>	<b><u>REPLACEMENT PARTS</u></b>	
		<b>Description</b>	<b>Part Number</b>
Float Kit (1/2 - 1 HP)	6226	Propeller	A-24417-P
Float Kit (2 HP)	6230	Zinc Anode	41896-p
Dock Mounting Kit	6225	Shackle	A-24412-P
Thermostat (on @ 25 off @ 35 f)	6215		
Thermostat (on @ 30 off @ 40 f)	6216		

The thermostat saves energy by shutting the D-Icer off automatically when the air temperature is above freezing and on when the air temperature is below freezing.

If you have any questions, please call the Customer Service department toll free at 1-800-628-5188.

### **Taylor Made Products**

65 Harrison Street  
Gloversville, NY 12078  
A Member of The Taylor Made Group  
www.taylormadeproducts.com

© 2011 Taylor Made Group, LLC.  
Gloversville, NY 12078.

### **Warranty**

Thank you for purchasing a Taylor Made Products D-Icer. Our oil-free units are warranted for a period of two (2) years from the date of purchase. Should a defect arise, DO NOT SEND THE D-ICER BACK TO THE PLACE OF PURCHASE. Please call Taylor Made Products at 1-800-628-5188 for a return authorization number.

For two (2) years from the date of purchase, Taylor Made Products will, at its discretion, repair or replace for the original consumer, free of charge, any part or parts found upon examination to be defective in material or workmanship or both. This warranty does not include the zinc anode, ropes, electrical cord, propeller or failure due to misuse, mishandling, or improper storage or installation. Freight on defective products is the responsibility of the consumer (UPS is the preferred method of returning a product to us). Repaired or replacement products will be shipped back to the consumer freight prepaid. Proof of purchase is required.

TAYLOR MAKES NO EXPRESS OR IMPLIED WARRANTIES OTHER THAN WARRANTIES SET FORTH HEREIN, INCLUDING, WITHOUT LIMITATION, THE WARRANTIES OF MERCHANTABILITY, FITNESS FOR A PARTICULAR PURPOSE, OR FROM ANY COURSE OF DEALING OR TRADE USAGE.

TAYLOR SHALL NOT BE LIABLE FOR SPECIAL, INDIRECT, INCIDENTAL, PUNITIVE OR CONSEQUENTIAL DAMAGES, INCLUDING, WITHOUT LIMITATION, DAMAGES FOR LOSS OF OPPORTUNITY OR BUSINESS PROFITS, BUSINESS INTERRUPTION OR ANY OTHER LOSS EVEN IF TAYLOR HAS BEEN ADVISED OF THE POSSIBILITY OF SUCH DAMAGES.

IN NO EVENT SHALL TAYLOR BE LIABLE FOR ANY AMOUNT IN EXCESS OF THE PURCHASE PRICE PAID.